

CB Ceramic Band Heater

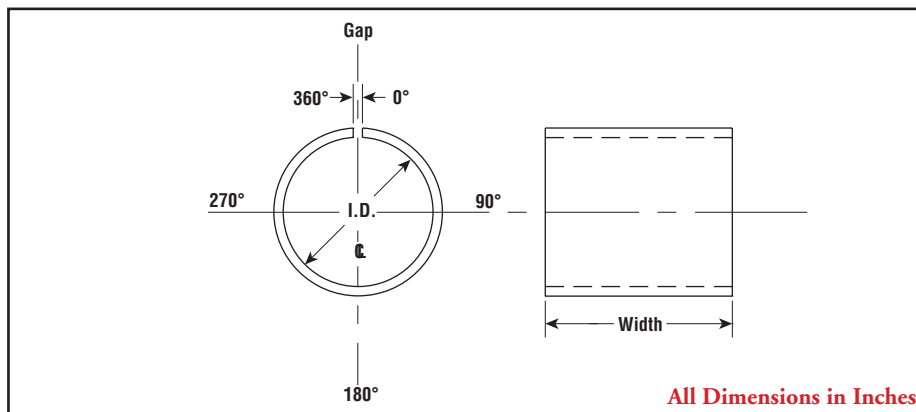

- 3-12" Barrel Dia.
- 1-1/2 - 6" Widths
- 500 - 5,000 Watts
- 120 to 600 Volts
- 18 - 40 W/In²
- Ceramic Fiber Insulated
- Up to 1600°F Band Operating Temp.
- Corrosion - Resistant Alloy Shell

Dimensions



Applications

- Blow Molding
- Die Heads
- Extruders
- Heating Pipes
- Injection Molding

Features

Type CB ceramic band heaters are best suited for applications up to 1600°F. Band operating temperatures and provide even heating on injection and extrusion molding barrels. The ceramic segments and high temperature resistance wires are capable of highly efficient heat transfer. Ceramic fiber insulation, 1/4" thickness, provides an additional 25% energy savings over non-insulated types. Ceramic bands also contribute a radiant heating effect to the object being heated. They can be constructed in greater widths, allowing fewer heaters per zone, wider heating patterns, and simplified wiring.

Energy Efficient, 25% Savings

Radiant Heating Principle

Uniform Heating Pattern

Available in **Special** Configurations

Thermal Insulation

1600°F Band Operating Temperatures

Flexible

Corrosion-Resistant Alloy Shell

High Temperature Resistance Wires

Construction

The use of ceramic inserts to support high temperature resistance wire allows the Chromalox Type CB ceramic heater band to operate at high temperatures reaching 1500°F. Corrosion resistant metal is slit along the edges to allow easy fitting of the shroud to the object being heated.

Insulation — 1/4" of ceramic fiber is placed between the inserts and the shroud to provide a 25% energy savings over non-insulated heater bands. Additional insulation and metal liners can be supplied as an option.

Clamping Method — Mounting flanges are standard on Chromalox ceramic bands. Other clamping methods are available.

Terminations — Due to the high temperature capabilities of ceramic insulated heat bands, the use of lead wires is not recommended. When leads must be supplied, Chromalox will exit the heater with ceramic wire insulating beads, and make a junction with the nickel alloy lead wire at a point outside the shroud. Terminals are generally best located 180° from the gap. Alternate locations are possible, consult factory.

Sensor Holes — Sensor holes should be positioned in the gap, and a shroud be supplied as a shell overlap construction. For holes through the elements, consult factory.

CB Ceramic Band Heater

Variations

One-Piece

Standard completely flexible construction consists of flange lockup, 1/4" thick ceramic insulation, 1/4-20 screw terminals, located 180° from gap, on width center line.

Max. I.D. 21"
Min. Width 1-1/2"

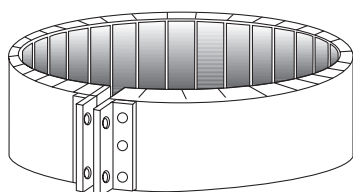

Two-Piece

Easy to apply when an obstruction prohibits the application of 1-piece heater. Heaters can be supplied with any termination or clamping variation. 2-piece heaters are rated at half of the voltage and each half is rated half of the total wattage. Larger diameters made in multiple segments.

Min. I.D. 4"
Width 1-1/2"
Max. I.D. 44"

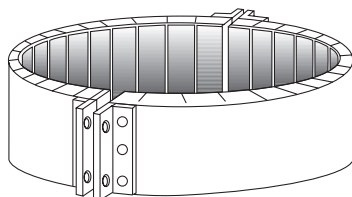

Partial Coverage

Allows for the heating of the accessible portion of machine when full coverage is not possible. Heaters supplied with standard clamping and termination.

Min. length 6"
Max. length 21"

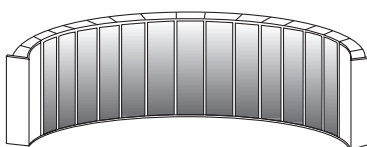

Liner

Stainless steel liners inhibit contamination of the ceramic tiles.

Min. I.D. 3"
Width 1-1/2"
Max. I.D. 21"

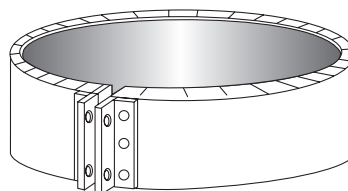

Special Insulation

1/2" ceramic fiber insulation can be inserted. The thickness of the heater will expand to 3/4". When 3/4" ceramic fiber and an inner liner is inserted the heater will be 7/8" thick.

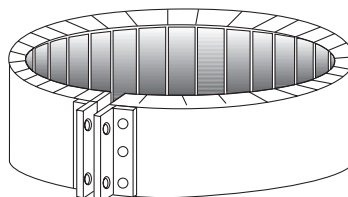

Clamping

Bent-Up Flange - F

Flange clamping is standard construction on ceramic heaters

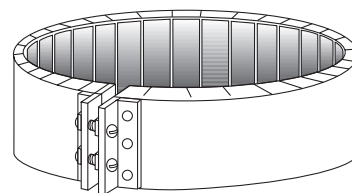

Built-In Bracket - BB

Mounting bracket with barrel nut lockup, and 1/4-20 screws. Supplied in any construction or termination variation.

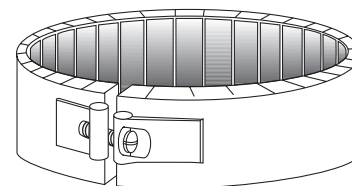

Latch and Trunion - LT

Quick Release Spring loaded latch & trunion. Recommended I.D. 12" or greater.

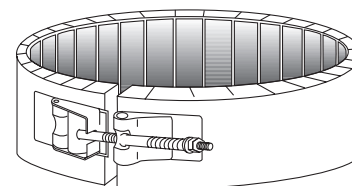

CB

Ceramic Band Heater (*cont'd.*)

Terminations

Tandem T-2

Tandem terminals located 180° from gap, on center line with length of heater. Available with 1/4-20 post terminals. Standard on widths under 3".

Min. I.D. 3"

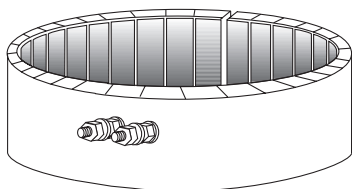

Euro Plug - EP

Quick disconnect cup assembly is a safe way to provide power to heater.

Min. Width 1-1/2"

Max. Amps 15 at 240V, Max. Volts 240

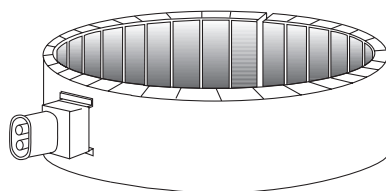

Options

Terminal Box Protection - TB

Designed in standard height of 1-3/4" high, with 5/8" conduit knockout for standard metal conduit connections. Protects terminals from damage, spill leakage, grounding or short circuiting. Available for single or 3-phase construction. For conduit connections, consult factory.

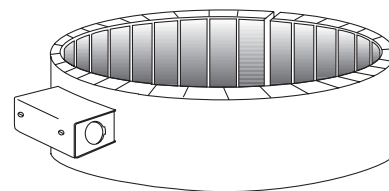

Parallel T-3

Parallel terminals located 180° from gap with width of heater. Available with 1/4-20 post terminals. Standard on all heaters greater than 3" width.

Min. I.D. 3"

Min. Width 3"

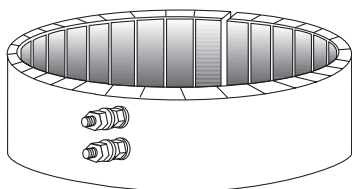

Lead Types

Stainless Steel Metal Braid - C

Provides abrasion resistant protection of fiberglass leads. Leads exit one point of heater surface through a strain relief. 10" braid over 12" leads, standard.

Min. I.D. 3"

Min. Width 1-1/2"

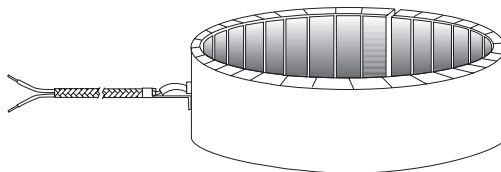

Standoff Terminals - SO

Provides relief from direct heat. Available on any construction or clamping variation. Single or 3-phase power, single or dual voltage.

Min. I.D. 3"

Min. Width 3"

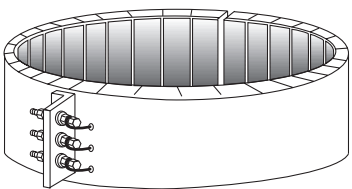

Metal Flexible Conduit - M

Stainless steel or galvanized. Flexible metal conduit to protect leads from abrasion. Available on any construction or clamping variation. 10" metal conduit over 12" fiberglass leads, standard.

Min. I.D. 3"

Min. Width 1-1/2"

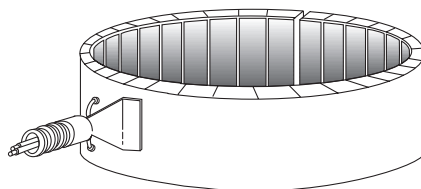

CB Ceramic Band Heater *(cont'd.)*

Options *(cont'd.)*

Shroud Overlap

Shroud overlap designed to accommodate a thermocouple hole in gap. This is the preferred way of adding a thermocouple hole. Heaters can be supplied with any termination or clamping variation.

Min. I.D. 5"
Width 1-1/2"
Max. I.D. 21"

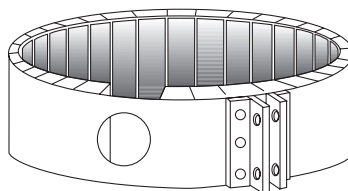

Ceramic Caps - CC

Protects against electric shock, when used with insulated wire. Can be rotated at any angle - Screw size 1/4-20 standard.

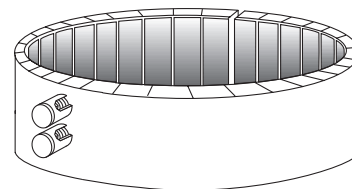

How to Order Ceramic Bands

1. Order by Catalog Code and PCN
2. Specify quantity
3. Specify Inside diameter (ID)
4. Specify Width (1/2" increments)
5. Wattage - 2-piece bands each half is rated one-half the wattage.
6. Voltage on 2-piece bands, we recommend each piece is rated at half the operating voltage.
7. Terminal type - post terminals are standard, specify terminal location.
8. Standard 1/4" insulated or optional 1/2" insulation.
9. Indicate size and location of thermocouple holes, cutouts, partial coverage, gaps or other special features - Fax Drawing.

Specifications

Sheath Material	Corrosion resistant alloy shroud
Maximum Temperature	1600°F
Insulation Material	Thickness of heater with 1/4" insulation = 5/8"
	Thickness of heater with 1/2" insulation = 3/4"
Minimum I.D.	3"
Minimum Width/Tolerance	1-1/2" wide
	Width in 1/2" increments
	Width tolerance: ± 1/8"
Standard Gap When Tightened	3/8" ± 1/8"
Resistance Tolerance	NEMA standard + 10% -5%
Wattage Tolerance	NEMA standard +5% -10%
Watt Density	Depends on power, operating temperature and heater size. See ordering information.
Maximum Volts	600 volts
Maximum Amps	25 amps